



2100 BALEBUSTER

[farm & ranch]
[erosion control]



The 2100 Balebuster.....Making Cattle Feeding and Erosion Control Faster, Easier, and More Economical THAN EVER!

Exclusive Features Available ONLY on the Haybuster 2100 Balebuster:



The 2100 Balebuster is three-point mounted, making it easy to maneuver and back into tight places. This semi-mounted unit transfers approximately 55% of the 2100's operating weight directly to the tractor, keeping the weight off the Balebuster.



The patented Shredder Chamber has a 3-chain slatted conveyor that provides the needed traction to handle all round bales, hard or soft core. The chamber is 15% larger than previous models, reducing spillage and making hay and straw placement much easier. It processes hay into usable rations, making your hay go farther and reducing your costs.



Spreads straw up to 50 feet for excellent erosion control. Preventing accelerated soil erosion and minimizing sedimentation is a primary concern for farmers, making the 2100 the perfect solution.

Why a 2100 Balebuster?

Haybuster has been a part of hard working hay processing equipment for 37 years. Farmers and ranchers have come to depend on our durability and performance.

We know that cutting edge technology, high efficiency, and getting the most value for every dollar you spend are enormous factors when you purchase farm equipment.

That's why we put all of those and more into the 2100 Balebuster.

Here are some of the benefits that make your decision to buy the 2100 balebuster the right one:



Processing your hay with the 2100 chops the forage into selected cut lengths, mixes drier outside layers with inner, fresher layers, removes dust and molds, and prevents cattle from sorting..... making your hay go farther.



The 2100 gives you very good uniformity by putting out a consistent windrow, ensuring that each animal gets its fair share.



Processing your straw with the 2100 removes most of the twine from the straw, saves wear and tear on tractors and loaders, keeps your livestock clean and comfortable, and allows you to apply bedding when needed, instead of just when scheduled.

Here's what they say...

We had the older model two point balebuster, then purchased the 2100, it definitely feeds better, grinds faster and throws straw farther. It is more stable when loading, with the two hydraulic cylinders on the loading arms. We like the 2100 Balebuster, it's a good machine.

– Gary Kesteloot, Marshall MN



The 2100 balebuster is self-loading and only requires one person to operate. Its heavy-duty caster wheels and very large 9.5 x 14-8 ply tires combine to easily navigate over boggy ground and rough terrain.

The unit's heavy-duty offset rotor, flails, and reduced flair tip clearance combine to throw straw further and process both dry and wet bales.

Here's what they say...

We own 4 Haybuster Balebusters, 2- 2100's and 2 of the previous model. The 2100 is a good machine, it's solid and more durable, We work them hard and in rough conditions.

We process around 8000 bales a year (erosion control) and we like how the 2100 performs.

– Bruce Hykus, Hykus Farms, Lakeville MN



Just remember...

With Haybuster products, you're not alone. Your local dealer is available to answer your questions and provide parts and service support. They also have access to the technical support staff at Haybuster.

2100 SPECS

WEIGHT

Total 3,700 lbs (1,679 kg)

SHIPPING DIMENSIONS

Width 8 ft 5 in (2.6 m) loader & deflector folded.

Length 12 ft 9 in (4.01 m)

Length 8 ft 5 in (2.6 m) caster wheels removed.

Height 6 ft 5 in (1.96 m) loader folded.

TRANSPORT DIMENSIONS

Width 10 ft 8 in (3.25 m)

Length 12 ft 9 in (4.01 m)

Height 6 ft 5 in (1.96 m) loader folded

WORKING DIMENSIONS

With Bale Width 13 ft (3.96 m)

Length 12 ft 9 in (4.01 m)

Height 9 ft 8-3/4 in (3.05 m)

CHASSIS FEATURES

Hitch Semi-Mounted, attaches to lower Lift Links of Tractor's 3-PT

Hitch Tires 2) 9.5 x 14 - 8 Ply Wheels
- 2) 6 x 14 - 5 Bolt Drop Center

Bearings Tapered Roller Axle- Caster

BALE LOADER

Type Hydraulic with mechanical linkage.

Bale Tines 2, fixed width.

Hydraulic Cylinder 2) 2-1/2 in x 16 in (6.35 cm x 40.64 cm) Double Acting

BALE CONVEYOR

Type 3 Roller Chains with Bolt-on Cross Slats

Drive Hydraulic Motor with Hydraulic Flow Control

BALE SHREDDER CHAMBER

Max. Bale Size 5-1/2 ft long x 6-1/2 ft dia (1.68 m x 1.98 m)

Max. Bale Weight 1,500 lbs (682 kg) Rotor Length 78 in (1.83 m)

Rotor Diameter (Flails extended) 25-1/2 ft (64.77 cm)

Rotor Bearing Ball, 1-3/4 ft (4.44 cm)

Number of Flails 30

Flail Type Heavy Duty Flails, 7/16 in (11.11 mm) Thick, 3 lbs (1.36 kg), Heat Treated Spring Steel, Swinging

Number of Stripper Plates 1

Number of Slug Bars 5

Deflector Shield 6 Adjustment Positions through 120° range

Max. Horizontal Spread straw up to 50'

Loader 1 set of Tractor Hydraulic Outlets

Bale Conveyor 1 set of Tractor Hydraulic Outlets

Bale Conveyor Speed Adjustable Hydraulic Flow Control Valve

Slug Bar Shim adjustable

Deflector Shield Position Hand Lever with Position Settings

SPECIFICATIONS [2100 Balebuster]

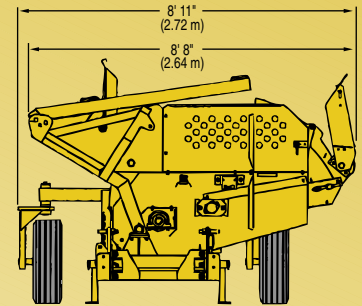
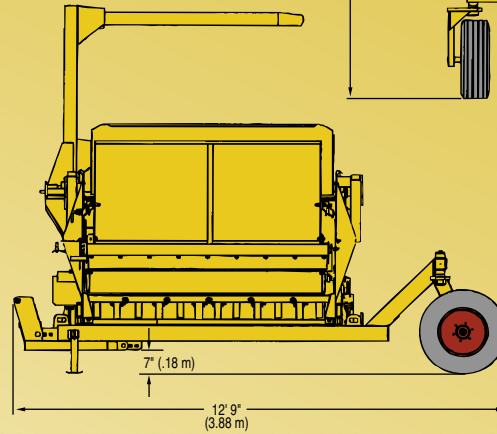
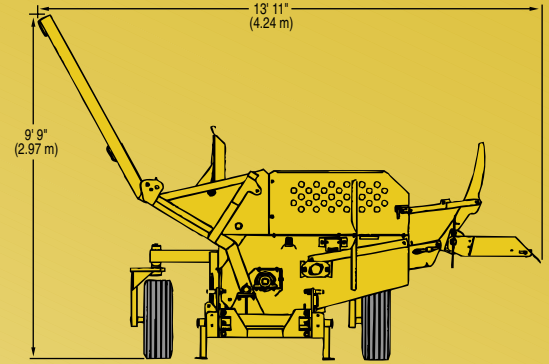
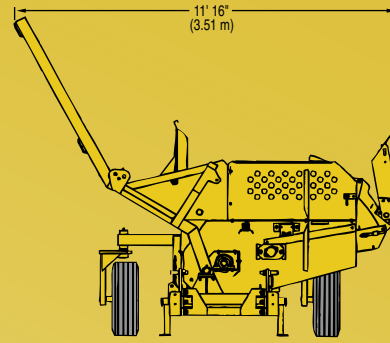

HAYBUSTER®

DURATECH® INDUSTRIES

PO Box 1940
Jamestown, ND 58402-1940
Phone: (701) 252-4601
Fax: (701) 252-0502
Website: www.haybuster.com

DuraTech Industries International, Inc. reserves the right to change its products or their specifications at anytime without notice or obligation. Illustrations, specifications, and descriptions contained herein were accurate at the time of publication, but are subject to change without notice. Illustrations may include optional equipment or accessories and may not include all standard equipment.

UP 3000 1/05

REQUIREMENTS FOR OPERATION TRACTOR

PTO Horsepower required - 65 to 155

Three Point Hitch - CAT II / III

Min. Hitch Lift Capacity - 4,000 lbs (1,818.18 kg)

PTO Type - 1000 RPM, 1-d in dia Shaft with 21 Splines

Min. Hydraulic Output - 8 gpm at 1800 psi (46lpm x 10,345 kpa)

Hydraulic Remote Controls - 2 Double-Acting Control Valves with Quick Coupler Outlets

Tractor Weight - Must be of equal or greater weight than that of a 2100 Balebuster and one bale.

OPTIONS

Stripper channel kit, quick tach Category II/III, wide deflector belt.